

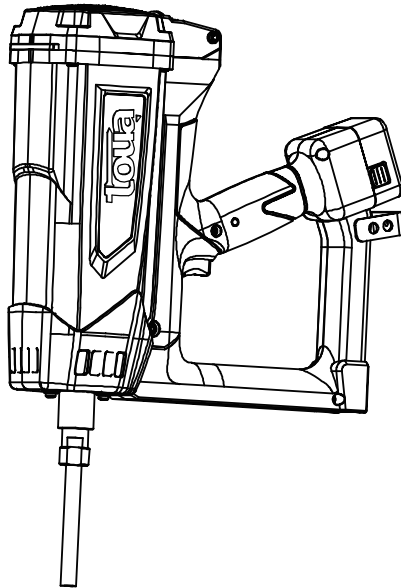

**MODEL GSN65-D
GAS CONCRETE NAILER**



SAFETY OPERATE MANUAL

CONTENTS

ITEM	PAGE
1. SAFETY	1
2. SPECIFICATION	6
3. GENERAL OPERATION MANUAL	7
4. MAINTENANCE	15
5. EXPLODED DRAWING AND PARTS LIST	18
	...

IMPORTANT INFORMATION MUST TO KNOW BEFORE TO READ



Read and understand tool labels and all of operating instructions, safety precautions and warnings in this manual before operating or maintaining this nailer.

Failure to follow warnings could result in DEATH or SERIOUS INJURY.

Most accidents that result from the operation and maintenance of Nailers are caused by the failure to observe basic safety rules or precautions. An accident can often be avoided by recognizing a potentially hazardous situation before it occurs, and by observing appropriate safety procedures.

Basic safety precautions are outlined in the "SAFETY" section of this Manual.

Hazards that must be avoided to prevent bodily injury or machine damage are identified by DANGERS and WARNINGS on the Nailer and in this Manual.

Never use this Nailer for applications other than those specified in this Manual.

DEFINITIONS OF SIGNAL WORDS

DANGER indicates an imminent hazardous situation which, if not avoided, will result in death or serious injury.

WARNING indicates a potentially hazardous situation which, if not avoided, could result in death or serious injury.

CAUTION indicates a potentially hazardous situation which, if not avoided, may result in minor or moderate injury, or may cause machine damage.

NOTE emphasizes essential information.

EXPLANATION OF THE FUNCTION OF THE TOUA NAILER

This tool has a FULL SEQUENTIAL ACTUATION MECHANISM (on the nailer body mark del operator ▽). First, press the push lever (push lever be called apart of the full sequential actuation mechanism) against the workpiece; press down of the nailer, and then pull the trigger to drive the nail. Follow the same sequence to continue driving nails after the push lever and trigger are return back in place.

SAFETY

IMPORTANT SAFETY INSTRUCTIONS FOR USING NAILERS

READ ALL INSTRUCTIONS



This Nailer is powered by internal combustion device.

This Nailer shall only be used with dispensers for combustible gas which are listed in this manual.

DANGER

1. OPERATORS AND OTHERS IN WORK AREA MUST WEAR SAFETY GLASSES WITH SIDE SHIELDS.



When operating the Nailer, always wear safety glasses with side shields, and make sure others in work area wear safety glasses.

Safety glasses must conform to the requirements of China's National Standards Institute, and provide protection against flying particles both from the front and side.

The employer must enforce the use of safety glasses by the Nailer operator and others in work area.

2. NEVER USE IN PRESENCE OF FLAMMABLE LIQUIDS OR GASES.



This Nailer must not be used in a combustible environment or in presence of flammable liquids or gases, e.g. lacquer, paint, benzene,

thinner or gasoline.

This Nailer produces hot exhaust gases that may ignite flammable materials and produces sparks during operation.

3. DO NOT TOUCH AROUND THE EXHAUST OUTLET.



This Nailer produces hot exhaust gases that may flammable materials.

The push lever and nose will become hot and get heated up after

prolonged or rapid use.

Do not touch with bare hands.

4. EXPLOSION AND FIRE HAZARD.



The fuel cell is an aerosol dispensers with flammable contents.

Pressured container and the propellant will remain in the fuel cell. Failure to follow instructions may result in explosion or fire.

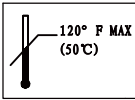

Keep the Nailer, fuel cells and battery away from sunshine and from temperature exceeding 120°F (50°C).

Fuel cell and/or battery may burst, releasing flammable gas.

Do not pierce or burn the container, even after use.

Do not incinerate, refill, reclaim or recycle the fuel cell.

Do not spray to a naked flame or any incandescent material.

Keep away from ignition sources
No smoking.

Keep out of the reach of children.



WARNING

5. NEVER POINT TOOL AT YOURSELF OR OTHERS IN WORK AREA.



Always assume the Nailer contains fasteners.

Never point the Nailer at yourself or others, whether it contains fasteners

or not.

If fasteners are mistakenly driven, it can lead to severe injuries.

Never engage in horseplay with the Nailer.

Respect the Nailer as a working implement.

6. KEEP FINGERS AWAY FROM TRIGGER WHEN NOT DRIVING FASTENERS TO AVOID ACCIDENTAL FIRING.

Never carry the Nailer with finger on trigger since you could drive a fastener unintentionally and injure yourself or someone else.

Always carry the Nailer by the handle only.

7. ALWAYS WEAR EAR AND HEAD PROTECTION.

Always wear ear protection to protect your ears from loud noise.

Always wear head protection to protect your head from flying objects.

8. USE OUTSIDE OR WELL-VENTILATED AREAS.



This Nailer shall not be used in enclosed or poorly ventilated areas.

This Nailer exhausts carbon monoxide which is a danger to health when inhaled.

Do not inhale.

9. STORE NAILER PROPERLY WITH FUEL CELL AND BATTERY REMOVED.

When not in use, the Nailer, fuel cell and battery should be store in tool case and in a dry place.

Store indoors at temperature 41°F (5°C) ~ 77°F (25°C).

Keep the Nailer, fuel cell and battery out of direct sunlight and out of in a vehicle.

Keep out of reach of children.

Look the storage area.

10. KEEP WORK AREA CLEAN.

Cluttered areas invite injuries. Clear all work areas of unnecessary tools, debris, furniture, etc.

11. KEEP VISITORS AWAY.

Do not let visitors handle the Nailer.

All visitors should be kept safely away from work area.

12. DRESS PROPERLY.

Do not wear loose clothing or jewelry as they can be caught in moving parts.

Rubber gloves and nonskid footwear are recommended when working outdoors.

Wear protective hair covering to contain long hair.

13. CHECK PUSH LEVER BEFORE USE.

Remove fuel cell and battery, and then make sure the push lever operates properly. Never use the Nailer unless the push lever is operating properly, otherwise the Nailer could drive a fastener unexpectedly. Do not tamper with or remove the push lever, otherwise the push lever becomes inoperable.

14. KEEP ALL SCREWS AND COVERS TIGHTLY IN PLACE.

Keep all screws and covers tightly mounted. Check their condition periodically.

Never use the Nailer if parts are missing or damaged.

15. DO NOT LOAD FASTENERS WITH TRIGGER OR PUSH LEVER DEPRESSED.

When loading fasteners into the Nailer,

- 1) do not depress the trigger;
- 2) do not depress the push lever;
- 3) keep the Nailer pointed downward.

16. KEEP FACE, HANDS AND FEET AWAY FROM FIRING HEAD DURING USE.

Never place your face, hands or feet closer than 8 inches (200 mm) from the firing head.

A serious injury can result if the fasteners are deflected by the workpiece, or are driven away from the point of entry.

17. PLACE NAILER PROPERLY ON WORKPIECE.

Do not drive fasteners on top of other fasteners or with the Nailer at too steep of an angle; the fasteners can ricochet and hurt someone.

18. DO NOT DRIVE FASTENERS INTO THIN BOARDS OR NEAR CORNERS AND EDGES OF WORKPIECE.

The fasteners can be driven through or away from the workpiece and hit someone.

19. NEVER DRIVE FASTENERS FROM BOTH SIDES OF A WALL AT THE SAME TIME.

The fasteners can be driven into and through the wall and hit a person on the opposite side.

20. CHECK FOR LIVE WIRES.

Avoid the risk of severe electrical shock by checking for live electrical wires that may be hidden by walls, floors or ceilings. Turn off the breaker switch to ensure there are no live wires.

21. DO NOT OVERREACH.



Keep proper footing and balance at all times. Do not allowed operate the nailer on the scaffold and ladder.

22. NEVER USE NAILER WHICH IS DEFECTIVE OR OPERATING ABNORMALLY.

If the Nailer appears to be operating unusually, making strange noises, or otherwise appears defective, stop using it immediately and arrange for repairs by a TOUA authorized service center.

23. TAKE FUEL CELL AND BATTERY OUT OF NAILER WHEN:

- 1) doing maintenance and inspection;
- 2) clearing a jam;
- 3) it is not in use;
- 4) leaving work area;
- 5) moving it to another location;
- 6) handing it to another person.

Never attempt to clear a jam or repair the Nailer unless you have taken fuel cell and battery out of the Nailer and removed all remaining fasteners from the Nailer.

The Nailer should never be left unattended since people who are not familiar with the Nailer might handle it and injure themselves.

24. KEEP ALERT.

Operate the nailer only in good physical and mental state.

Do not operate the Nailer when you are tired. The Nailer should never be used by you if you are under the influence of alcohol, drugs or medication that makes you drowsy.

25. HANDLE NAILER CORRECTLY.

Operate the Nailer according to this Manual. Never allow the Nailer to be operated by children, individuals unfamiliar with its operation or unauthorized personnel.

26. NEVER USE NAILER FOR APPLICATIONS OTHER THAN THOSE SPECIFIED IN THIS MANUAL.

27. HANDLE NAILER CAREFULLY.

Do not drop the Nailer or strike the Nailer against hard surfaces; and do not scratch or engrave signs on the Nailer. Handle the Nailer carefully.

28. MAINTAIN NAILER WITH CARE.

Keep the Nailer clean and lubricated for better and safer performance.

29. USE ONLY PARTS, ACCESSORIES OR FASTENERS SUPPLIED OR RECOMMENDED BY TOUA.

Unauthorized parts, accessories, or fasteners may void your warranty and can lead to malfunction and resulting injuries.

Only service personnel trained by TOUA, distributor or employer trained personnel shall repair the Nailer.

30. NEVER MODIFY OR ALTER A NAILER.

Doing so may cause it to malfunction and personal injuries may result.

FUEL CELL IMPORTANT SAFETY INSTRUCTIONS

DANGER

- Fuel cell, fuel and propellant are flammable under pressure.

Explosion / Fire Hazard



Must to follow all instructions otherwise may result in fire and explosion when handling dispensers for combustible gas for the purpose of storage, transportation, inserting into and taking out of the tool and disposal.

- Do not smoke when handling the fuel cell.



WARNING

Do not inhale its contents.



In case of being inhaled ; the person affected should be taken into the open air and brought into a comfortable position.

**Expanding gases cause low temperatures.
Fluid gases might cause injuries when getting in touch with skin or eyes.**

In case of contact with skin ; wash the contact surface carefully with warm water and soap and apply a skin cream when dry.

In case of contact with eyes ; rinse the open eyes under running water.

Contact a doctor if necessary.

Store in well-ventilated area.

Store under 41°F (5°C) ~ 77°F (25°C) (e.g. Do not store under the direct sunlight or in a vehicle).

Do not expose to an open flame and sparks.

Do not puncture or open the fuel cell.

Do not refill, reclaim or recycle the fuel cell.

Dispose of according to local regulations for aerosol products.

Do not dispose of fuel cell with other scrap for recycling.

Keep out of reach of children.

IMPORTANT SAFETY INSTRUCTIONS FOR BATTERY CHARGER

WARNING

Death or serious bodily injury could result from improper or unsafe use of battery chargers.

To avoid these risks, follow these basic safety instructions:

READ ALL INSTRUCTIONS

1. This manual contains is important safety and operating instructions for battery charger Model 504.4.04.013.01.
2. Before using battery charger, read all instructions and cautionary markings on (1)nailer,(2) battery charger, (3) battery.
3. To reduce risk of injury, only use TOUA rechargeable battery type 504.4.04.011.01 . Other type of batteries may burst causing personal injury and damage.
4. Do not expose battery charger to rain or snow.
5. Use of an attachment not recommended or sold by the battery charger manufacturer may result in a risk of fire, electric shock, or injury to persons.
6. To reduce risk of damage to electric plug and cord, pull by plug when disconnecting battery charger.
7. Make sure cord is located so that it will not be stepped on, tripped over, or otherwise subjected to damage or stress.
8. An extension cord should not be used unless absolutely necessary.
Use of improper extension cord could result in a risk of fire and electric shock. If extension cord must be used make sure:
 - a) That blades of extension cord are the same number, size, and shape as those of plug on battery charger;
 - b) That extension cord is properly wired and in good electrical condition;
 - c) That wire size is large enough for AC ampere rating of battery charger as specified in table 1.

Table 1
**RECOMMENDED MINIMUM AWG SIZE FOR
 EXTENSION CORDS FOR BATTERY CHARGERS**

AC Input Rating Amperes		AWG Size of Cord			
Equal to or greater than	but less than	Length of Cord, Feet (Meter)			
		2.5(7.5)	50(15)	100(30)	150(45)
0	2	18	18	18	16
2	3	18	18	16	14
3	4	18	18	16	14

If the input rating of a battery charger is given in watts rather than in amperes, the corresponding ampere rating is to be determined by dividing the wattage rating by the voltage rating—for example:
 1,200 watts/120volt=10 Amperes

9. Do not operate battery charger with damaged cord or plug, should replace them immediately.
10. Do not operate battery charger if it has received a sharp blow, been dropped, or otherwise damaged in any way; take it to a qualified serviceman.
11. Do not disassemble battery charger; take it to a qualified serviceman when service or repair is required.
 Incorrect reassembly may result in a risk of electric shock or fire.
12. To reduce risk of electric shock, unplug charger from receptacle before attempting any maintenance or cleaning. Removing the battery will not reduce this risk.
13. Please read this Manual before using the battery charger.

IMPORTANT SAFETY INSTRUCTIONS FOR USE OF THE BATTERY AND BATTERY CHARGER

You must charge the battery before you use the Nailer. Before using the model 504.4.04.013.01 battery charger, be sure to read all instructions and cautionary statements on the battery and in this manual.

REMEMBER : ONLY USE TOUA BATTERY TYPE 504.4.04.011.01.

OTHER TYPES OF BATTERIES MAY BURST AND CAUSE INJURY!

Follow these instructions to avoid the risk of injury:

WARNING

Improper use of the battery or battery charger can lead to serious injury. To avoid these injuries:

1. **DO NOT** disassemble the battery.
2. **DO NOT** incinerate the battery, even if it is damaged or is completely worn out.
 The battery can explode in a fire.

3. **DO NOT** short-circuit the battery.
4. **DO NOT** insert any objects into the battery charger's air vents. Electric shock or damage to the battery charger may result.
5. **DO NOT** charge outdoors. Keep the battery away from direct sunlight and use only where there is low humidity and good ventilation.
6. **DO NOT** charge when the temperature is below 50°F (10°C) or above 104°F (40°C).
7. **DO NOT** connect two battery chargers together.
8. **DO NOT** insert foreign objects into the hole for the battery or the battery charger.
9. **DO NOT** use a booster transformer when charging.
10. **DO NOT** use an engine generator or DC power to charge.
11. **DO NOT** store the battery or battery charger in places where the temperature may reach or exceed 104°F (40°C).
12. **MUST TO DO** operate charger on standard household electrical power (120 volts). Using the charger on any other voltage may overheat and damage the charger.
13. **MUST TO DO** wait at least 15 minutes between charges to avoid overheating the charger.
14. **MUST TO DO** disconnect the power cord from its receptacle and cut off the charger power when the charger is not in use.

DISPOSAL OF THE EXHAUSTED BATTERY WARNING

Do not dispose of the exhausted battery. The battery must explode if it is incinerated. The product that you have purchased contains a rechargeable battery. The battery is recyclable. At the end of its useful life, under various state and local laws, it may be illegal to dispose of this battery into the municipal waste stream. Check with your local solid waste officials for details in your area for recycling options or proper disposal.

EMPLOYER'S RESPONSIBILITIES

1. Ensure that this MANUAL is available to operators and personnel performing maintenance.
2. Ensure that Nailers are used only when operators and others in work area are wearing EYE PROTECTOR.
3. Enforce the use of EYE PROTECTOR by operators and others in work area.
4. Keep Nailers in safe working order.
5. Maintain Nailers properly.
6. Ensure that Nailers which require repair are not further used before repair.

SAVE THESE MANUAL AND MAKE THEM AVAILABLE TO OTHER USERS AND OWNERS OF THIS TOOL!

SPECIFICATION

1. GAS CONCRETE NAILER

TYPE	GSN65-D
Type of power	Piston reciprocating
Applicable nails	See 2. Available Nails.
Nail Capacity	1 nails
Ambient temperature	-5 °C ~ 50°C (23°F to 120°F)
Dimensions	19.30 " (L) × 14.75 " (H) × 4.80 " (W) 490mm (L) × 375mm (H) × 122mm (W)
Weight	8.8lbs. (4kg Include battery)
Cycle Rate	1 nails/second
Battery Pack	NiMH 6V 1.5Ah

2. Available Nails

please ask dealer for detail

WARNING

Be sure to use only the genuine dealer nails as the above sizes. The use of any other nails can result in tool malfunction or nail breakdown, leading to serious injuries.
Only nails shown in the above table can be driven with this Nailer.

3. Fuel cell

Fuel Cell	Sold Separately, Specification as below: 1) Φ31.5mm x 165mm Pressure 16 ~18 bar, Using temperature range: 23°F (-5°C) ~120°F (50°C) Model No: FC165-1-1
	2) Φ31.5mm x 165mm Pressure 10.8 ~11.8 bar, Using temperature range: 23°F (-5°C) ~120°F (50°C) Model No: FC165-2-1

4. Charger

Input power source	AC110 ~240V / 50 ~60Hz/0.35A
Charge time	About 2hrs
Charging voltage	DC 6V
Charging current	DC 0.7A
Charger Weight	0.15Kg
Adapter Weight	0.085Kg

GENERAL OPERATION MANUAL

NOTE:

The information contained in this Manual is designed to assist you in the safe operation of the Nailer. Some illustrations in this Manual may show details or attachments that differ from those on your own Nailer.

NAME OF PARTS

1. Gas Heat Preservation Nail (MODEL: GSN65-D)

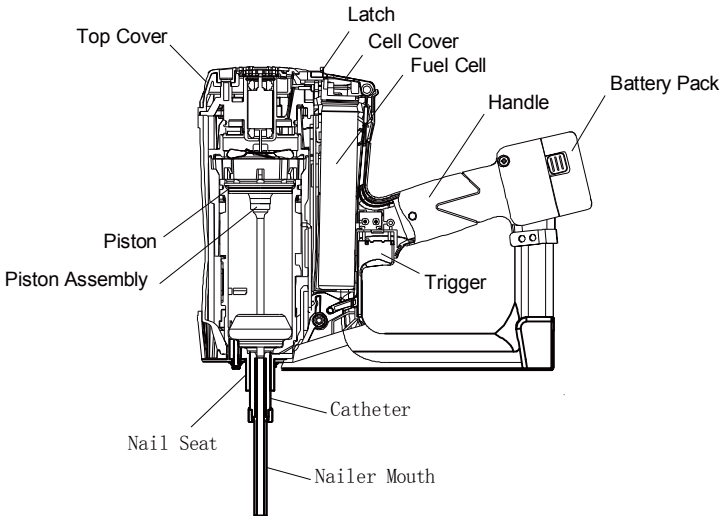

2. Battery Pack(504.4.04.011.01)

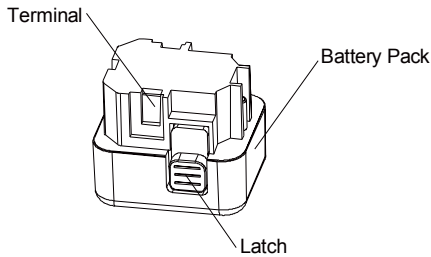

3. Battery Charger(504.4.04.013.01)(include Adapter and Charger Base)

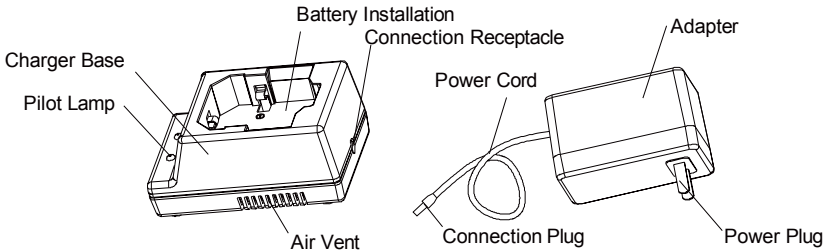

4. Accessories

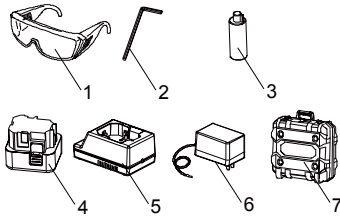

DANGER

Accessories other than those shown below can lead to malfunction and resulting injuries.

STANDARD ACCESSORIES

1. Safety Glasses	1
2. Allen Wrench for M5 Screw	2
3. Lubricant Oil	1
4. Battery	2
5. Charger	1
6. Adapter	1
7. Case	1

OPTIONAL ACCESSORIES

sold separately

1. Fuel Cell
2. Cleaner
(Code No. 504.6.04.001.01)

APPLICATIONS

Suggest application as below work piece with substrate connection combination:

Metal (sheet, section and wire netting etc.), wood, engineering plastics, plywood and nail accessory separate connection with concrete, brick setting, metal plate.

REMOVAL AND INSTALLATION METHOD OF BATTERY

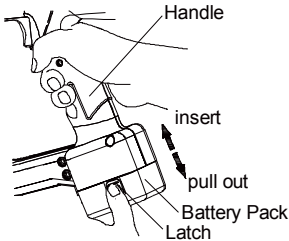

1. How to install the battery

Align the battery with the groove in tool handle and slip it into place. Always insert it all the way until it locks in place with a little click. If not, it may accidentally fall out of the tool, causing injury to you or someone around you.

2. How to remove the battery

Withdraw battery from the tool handle while pressing two button on the side of the battery.

CHARGING METHOD

NOTE: Before plugging into the receptacle, make sure the following points.

- The power source voltage is stated on the nameplate.
- The cord is not damaged.

WARNING



- Do not charge at voltage higher than indicated on the name plate. If charged at voltage higher than indicated on the nameplate, the charger will burn up.
- Do not use the electrical cord if damaged. Have it repaired immediately.
- TOUA charger(504.4.04.013.01) only use for TOUA battery (504.4.04.011.01), and TOUA battery(504.4.04.011.01) also only use for TOUA charger(504.4.04.013.01), if not, may cause the charger damage or battery burst.

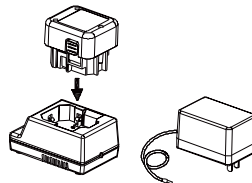

STEP:

1. Insert the battery into the charger base. Make sure it contacts the bottom of the charger base.
2. Insert the connection plug of adapter into the receptacle of the charge base.
3. Insert the power plug of the adapter into the plug seat.
4. Charging
 - When the plug of charger adapter has been inserted into the plug seat, charging will commence and the red&green pilot lamp will light on together.
 - In approx. 120 min. at 70°F (20°C), when the battery is fully charged, the red pilot lamp will go out and the green pilot lamp light on.

NOTE: The battery charging time becomes longer when a temperature is low or the voltage of the power source is too low.

When the green pilot lamp does not light on even if more than three hours has passed after start of the charging, stop the charging and contact your TOUA AUTHORIZED SERVICE CENTER.

5. Disconnect battery charger from the power plug.

CAUTION

Do not pull the plug out of the receptacle by pulling on the cord.

Make sure to grasp adapter plug when removing from receptacle to avoid damaging adapter.

6. Remove the battery from the battery charger.

Supporting the charger base with hand, pull out the battery from the charger base.

Regarding electric discharge in case of new batteries, etc.

As the internal chemical substance of new batteries and batteries that have not been used for an extended period is not activated, the electric discharge might be low when using them the first and second time. This is a temporary phenomenon, and normal time required for recharging will be restored by recharging the batteries 2 - 3 times.

How to make the battery perform longer

1. Do not recharge the batteries after they become completely exhausted.

When you find the power pilot lamp change from green to red on their nailer handle, should stop to operate the nailer and recharge its battery. If you continue to use the nailer and exhaust the electric current, the battery may be damaged and its life will become shorter.

2. Avoid recharging at high temperatures.

A rechargeable battery will be hot immediately after use. If such a battery is recharged immediately after use, its internal chemical substance will deteriorate, and the battery life will be shortened. Leave the battery and recharge it after it has cooled for a while.

CAUTION

■ **When the battery charger has been continuously used, the battery charger will be heated, thus constituting the cause of the failures. Once the charging has been completed, give 15 minutes rest until the next charging.**

■ **If the battery is recharged when it is warm due to battery use or exposure to sunlight, the pilot lamp may not light. The battery will not be recharged. In such a case, let the battery cool before charging.**

■ If the battery charger does not work while the battery is mounted correctly, it is probable that the battery or charger is malfunctioning. Take it to your TOUA authorized Service Center.

BEFORE OPERATION

Read section titled "SAFETY"

Make sure of the followings before operation.

WORKING ENVIRONMENT

WARNING



■ No flammable gas, liquid or other flammable objects at worksite.

■ Use outside or well-ventilated areas. Do not inhale.

■ Keep the Nailer, fuel cell and battery away from sunshine and from temperature exceeding 120°F (50°C).

■ Keep away from ignition sources. No smoking.

■ Clear the area of children or unauthorized personnel.

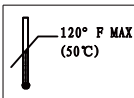

COLD WEATHER CARE

■ Do not store the Nailer, fuel cell and battery in a cold weather environment. Keep the Nailer, fuel cell and battery in a warm area until beginning the work.

■ If the Nailer, fuel cell and battery are already cold, bring it in a warm area and allow the Nailer to warm up before use. Observe temperature limit of max. 120°F (50°C).

Do not expose to an open flame and sparks!

CAUTION

- This Nailer may not drive completely below when:
 - at low temperature fuel cell lose the required propellant force;
 - at high temperature fuel cell overdose.
- Do not use the Nailer in the rain or where excessive moisture is present.
- This Nailer is not recommended for use at altitudes above 5,000 feet (1,500 m), or in temperature below 23°F (-5°C).

PREPARING THE FUEL CELL

Read section titled "FUEL CELL IMPORTANT SAFETY INSTRUCTIONS "

DANGER



■ The fuel cell is flammable.

■ Keep away from ignition sources.



- Do not spray to a naked flame or any incandescent material.
- Do not smoke when handling fuel cell.
- Keep stem of fuel cell away from face or skin. Expanding gases cause low temperatures. Do not contact with gases.
- Do not inhale.
- Keep out of reach of children.



CAUTION

- If the gas leaks from the metering valve or the gas cartridge after attached the metering valve, replace with the new metering valve.
- Do not attempt to reuse the metering valve. Replace with the new metering valve. To attach the metering valve to a fuel cell.

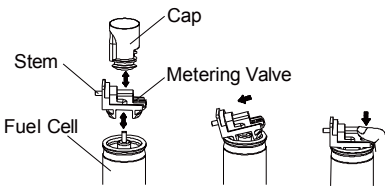

- (1) Separate the metering valve and the cap from the gas cartridge.
- (2) Stem downward, put the metering valve inclined forward to the bowl cover.
- (3) Press downward on the rear of the metering valve until it seals, no gas leakage.

Check the metering valve:

Press the metering valve stem on fuel cell two or three times against a stationary object and release.

If gas is not dispersed, fuel cell is empty. Replace it .

Observe Safety Regulations.

The fuel cell is now ready to insert into the Nailer.

PREPARING THE BATTERY

Read section titled "SAFETY, IMPORTANT SAFETY INSTRUCTIONS FOR BATTERY CHARGER".

You must charge the battery before use.

The charging method of battery is shown as "Charging Method" chapter.

WARNING

Never use Nailer after taking off the magazine.

TESTING THE NAILER

DANGER



Operators and others in work area **MUST** wear safety glasses with side shields which conforms to ANSI Z87.1 specifications.

WARNING

Never use Nailer unless push lever is operating properly.

The machine employs a preventive mechanism for unloaded operation.

The machine enters a state where the push lever cannot be pushed up.

CAUTION

Use caution not to throw the push lever tip onto any object.

Before actually beginning the nailing work, test the Nailer by using the checklist below. Conduct the tests in the following order. If abnormal operation occurs, stop using Nailer and contact a TOUA authorized service center immediately.

- (1) REMOVE FUEL CELL AND BATTERY FROM NAILER.

- ALL SCREWS MUST BE TIGHTENED.

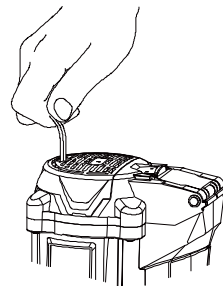

■ In push gun mouth down, tapping and pull the trigger necessary action is smooth

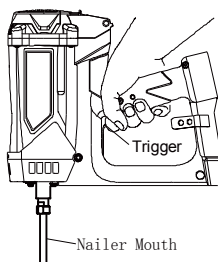

(2) Installing the battery.

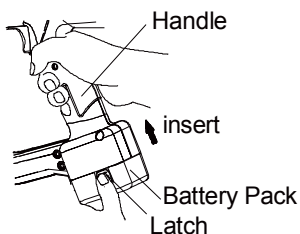

Do not operate the push lever or trigger while installing the battery.

Make sure the battery indicator light is flashing green. If the battery indicator light is flashing red, the battery doesn't have enough power and it needs to be charged.

BATTERY INDICATOR LIGHT

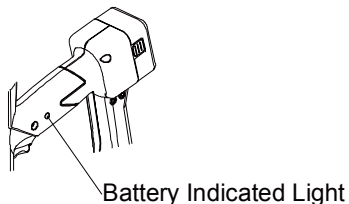

Flashing GREEN: Enough power remaining (The light turns steady during operation).
 Flashing RED: Insufficient power remaining (The light turns steady during operation).

(3) INSERT FUEL CELL INTO NAILER.

① Pulling the latch and open the cell cover.

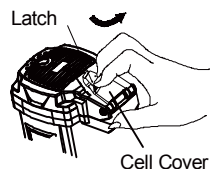

② Insert the fuel cell into nailer.

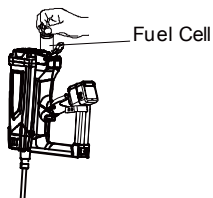

③ Insert the stem of fuel cell into the hole of adaptor.

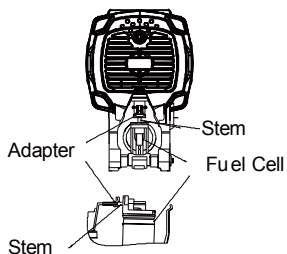

④ Close the cell cover.

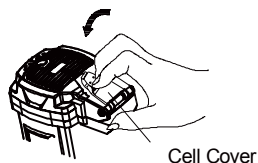

⑤ Lock up the latch.

(4) Leave the trigger finger, against the workpiece against gun mouth, press the nail gun, fan start at this time

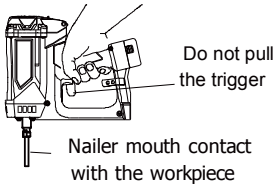

■ THE NAILER MUST NOT OPERATE.

(5) Gun mouth away from the workpiece
Next, keep the gun mouth down, leave the artifacts, wait 5 seconds or longer to pull the trigger. No reset if explosion, tapping arm, the cylinder did not open, abnormal nail gun .

■ THE NAILER MUST NOT OPERATE.

(6) Depress the push lever against the workpiece, downward nailer, pull the trigger.

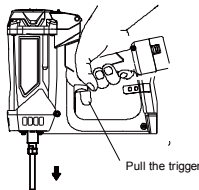

■ THE NAILER MUST OPERATE.

(7) If no abnormal operation is observed, you may load nails in the Nailer.
Drive nails into the workpiece that is the same type to be used in the actual application.

NAILER OPERATION

Read section titled "SAFETY".

DANGER



■ Operators and others in work area **MUST** wear safety glasses with side shields which conforms to ANSI Z87.1 specifications.

■ Never use in presence of flammable liquids or gases.

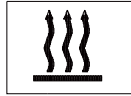

■ Do not touch around the exhaust outlet with bare hands. The push lever and nose will become hot and get heated up after prolonged or rapid use.

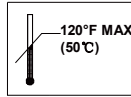

■ Do not allowed push and pull push lever with hand, otherwise will caused accidental firing, hurt someone .

■ Explosion and fire hazard Keep away from sunshine and from temperature exceeding 120°F (50°C).



■ Keep away from ignition source.
■ No smoking.

WARNING



■ NEVER point tool at yourself or others in work area.

■ Keep fingers **AWAY** from trigger when not driving nails to avoid accidental firing.



■ Use outside or well-ventilated area.

■ Do not inhale its contents.

■ Do not use the electrical cord if damaged. Have it repaired immediately.



■ Never place your face, hands or feet closer than 8 inches (200 mm) from firing head when using.

■ Do not drive nails on the top of other nails or with Nailer at too steep of an angle; nails can ricochet and hurt someone.

■ Do not drive nails into thin boards or near corners and edges of workpiece. Nails can be driven through or away from workpiece and hit someone.

■ Never drive nails from both sides of a wall at the same time. Nails can be driven into and through the wall and hit a person on the opposite side.

■ Never use Nailer which is defective or operating abnormally.

■ Do not use Nailer as hammer.

■ Disconnect battery and fuel cell from Nailer when:

it is not in use;

leaving work area;

moving it to another location;

handing it to another person.

■ Be careful of unwanted fastener.

If the nailer can not normal driving nail at the temperature below 23°F (-5°C), downward push lever against to the workpiece, quick press

downward nailer 2~3 times, pulling the trigger , the nails will be driven. Or use after put the nailer and fuel cell indoor 30 minutes.

This Nailer is equipped with a FULL SEQUENTIAL ACTUATION MECHANISM.

Explanation of FULL SEQUENTIAL ACTUATION MECHANISM nailing operation:

First, press the push lever against the workpiece;
Next, press downward nailer;
Then, pull the trigger to drive a nail.

The machine employs a preventive mechanism for unloaded operation.

The machine enters a state where the push lever cannot be pushed up in place. This takes place when the magazine is not loaded with nails or when the remaining number of nails becomes less than 2 or 3.

CAUTION

Use caution not to press the nailer mouth tip against to the workpiece when the nailer mouth lever cannot be pushed up in place.

METHODS OF OPERATION

This Nailer is equipped with the nailer mouth and does not operate unless the nailer mouth is depressed upward top dead center position. It is intermittent operation (Trigger fire) only.

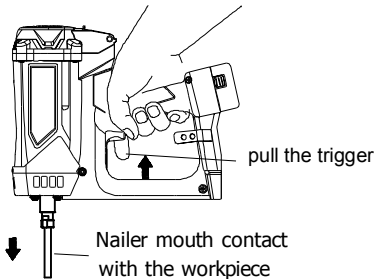

- (1) Position the nail outlet on the workpiece with finger off the trigger.
- (2) Depress the nailer mouth firmly until it is completely depressed.
- (3) Pull and squeeze the trigger to drive a nail.
- (4) Remove finger from the trigger.

To continue nailing in a separate location, move the nailer along the workpiece, repeating above steps (1)-(4) as required.

HEAT PRESERVATION NAIL REAL PLAY

Insert the nail insulation components heat preservation nail gun, until the end .

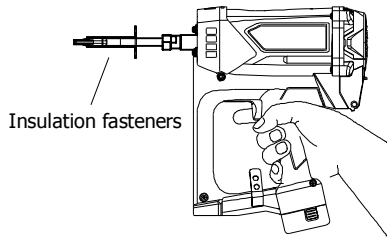

Insert heat preservation nail gun, together with the Insulation fasteners thermal insulation layer, and press it hard, let the heat preservation nail components and good contact with insulation layer, keep the gun and vertical metope.

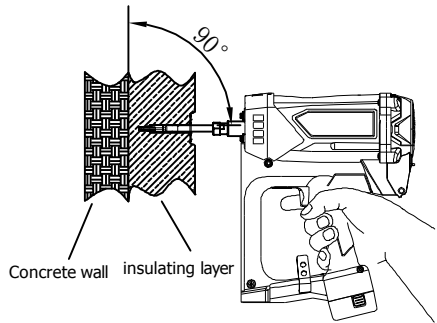

Pull the trigger. Insulation fasteners to move forward, through the insulation layer closely contact with concrete walls, firmly on the concrete wall with thermal insulation layer.

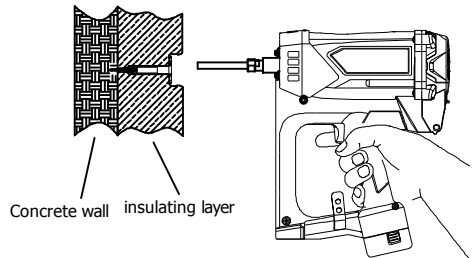

MUSING THE HOOK

CAUTION

Using the hook, can hang on the nailer to the work belt or scaffolding on work.

This nailer hook can left and right side by side mounting , as (a) and (b).

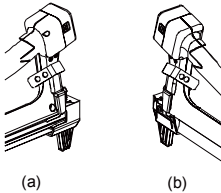

If need, can according to the following steps exchange :

- (1) Use accessory wrench (M5) loosen and pull out two screws;
- (2) Pull out the hook, reversal insert;
- (3) Insert the screws and tightening.

The screws must make sure be tightening to avoid the hook fall off cause to the nailer damage or hurt someone.

If the tool falls, there is a risk that malfunctions or parts damage can occur.

It is recommended that you also use fall- preventing wires, etc.

THE USE OF THE GUN NOZZLE

When loaded gun mouth, will first gun mouth inserted catheter until the gun in the mouth the steps, then lock the nut from the other end into the gun set mouth, spin lock nut with wrench. On the other hand, using a wrench unscrew the locking nut can remove gun mouth

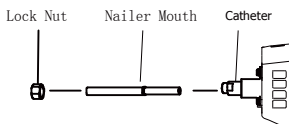

MAINTENANCE

NOTE:

- The information contained in this Manual is designed to assist you in the safe maintenance of the Nailer.
- Some illustrations in this Manual may show details or attachments that differ from those on your own Nailer.

MAINTENANCE AND INSPECTION

Read section titled "SAFETY".

DANGER



- **Never use and test in presence of flammable liquids or gases.**

- **Keep away from ignition source.**



- **No smoking.**

WARNING

Remove fuel cell, battery and all nails from Nailer when:

- Daily cleaning;
- Maintenance and Inspection;
- Clearing a jam.

1. Daily cleaning

Must regularly to clean nailer, remove the internal accumulation of smeary, carbon and dust, and to ensure the normal operate, extend nailer working life. Please use TOUA designated cleaner (504.6.04.001.01).

Follow the attachment Gas Concrete Nailer Cleaning Guide-a steps and methods to clean the nailer.

TOUA nailer cleaning intervals depends on the nailer operating environment and the firing quantity per week of nails. If using at the dirty environmental and firing large quantity per week, nailer cleaning intervals will be shorter.

Below is the cleaning time intervals form for you reference. If you according to the cleaning time intervals form to clean the nailer find the nailer is extremely dirty, the cleaning time intervals should be shorten, conversely, if find the nailer is very clean, extend cleaning time intervals.

		Operation Environment			
		very dirty	dirty	common	clean
Firing quantity per week	1000	1 Week	2 Week	1Month	2Month
	2000	1 Week	2 Week	1Month	1.5Month
	4000	1 Week	2 Week	3 Week	3 Week
	6000	1 Week	1 Week	2 Week	2 Week
	8000	1 Week	1 Week	2 Week	2 Week

Note After completion of each cleaning must drip the lubricating oil (504.6.03.001.01) to the nailer the place which shown in attachment Gas Concrete Nailer Cleaning Guide .

If you have any questions about of the cleaning operating procedures and methods, please contact with TOUA authorized service center.

2. Inspecting the magazine

- ① REMOVE FUEL CELL and BATTERY.
- ② Clean the magazine.
Remove paper chips or wooden chips which may have accumulated in the magazine.
- ③ Lubricate it with TOUA designated lubricant oil.

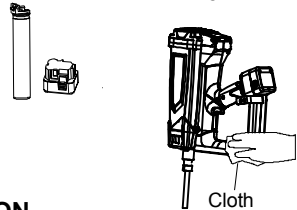

CAUTION

Check that the nail feeder slides smoothly by pulling it with finger. If not smooth, nails can be driven at an irregular angle and hurt someone.

3. Storing

DANGER



- **Store Nailer properly with nails, fuel cell and battery removed .**
- **The fuel cell is an aerosol dispensers with flammable contents.**
- **When not in use, the Nailer, fuel cell and battery should be stored in tool case and in a dry place and below temperature 122°F (50°C).**
- **Store indoors at temperature 41°F (5°C) ~ 77°F (25°C) .**
- **When not in use for an extended period, apply a thin coat of the lubricant to the steel parts to avoid rust.**
- **Do not store the Nailer 、 fuel cell and battery in a cold weather environment.**

- When not in use, the Nailer, fuel cell and battery should be stored in a warm and dry place.
- Keep it out of reach of children.

4. WARNING LABEL

Change the WARNING LABEL if missing or damaged. A new WARNING LABEL is available from a TOUA authorized service center.

5. Maintenance chart

ACTION	WHY	HOW
Keep nailer mouth working properly.	Promote operator safety and efficient Nailer operation.	Daily cleaning.
Make sure all screws are tightening.	Avoid the nailer being damaged, make sure the safety.	Periodical inspection.

6. Operator troubleshooting

See page 18.

CAUTION

Repair, modification and inspection of TOUA Power Tools must be carried out together with the replacement parts list by an TOUA Authorized Service Center.

In the operation and maintenance of power tools, the safety regulations and standards prescribed in each country must be observed.

MODIFICATIONS:

TOUA Power Tools are constantly being improved and modified to incorporate the latest technological advancements.

Accordingly, some parts (i.e. code numbers and/or design) may be changed without prior notice.

SERVICE AND REPAIRS

WARNING

- **Only service personnel trained by TOUA, distributor or employer shall repair the Nailer.**
- **Use only parts supplied or recommended by TOUA for repair.**

All quality Nailers will eventually require servicing or replacement of parts because of wear from normal use.

NOTE

Specifications are subject to change without any obligation on the part of TOUA.

Operator troubleshooting

PROBLEM	CHECK METHOD	CORRECTION
Nailer operates, but no nail is driven.	Check for proper nails.	Use only recommended nails.
	Check for a jam .	Clear a jam.
	Check whether tanks have spirit	Replace the new tanks
	Check if the driver blade piston is down or not.	Push the driver blade with a slotted-head screwdriver, and put back the piston to the highest position.
Skipping nails. Intermittent feed.	Check for proper nails.	Use only recommended nails.
	Check for returning of piston.	Too low temperature, warm up fuel cell under 50°C (120°F).
	Check for moving of piston smoothly.	Replace piston assembly.
Nail jam. Driven nail is bent.	Check for proper nails.	Use only recommended nails.
	Driver blade worn?	Replace piston assembly.
The operation of the nailer mouth not smooth.	Nailer mouth burst?	Replace nailer mouth
	Check nailer mouth moving track, debris?	Clean the foreign body.
Fan is working, light indicator shows GREEN yet it doesn't drive a nail or operation unstable.	Check for returning of piston.	Pull the trigger all the way. Too low temperature, warm up fuel cell under 50°C (120°F).
	Check fuel cell, insufficient?	Exchange it with a new fuel cell.
	Check spark plug wire, worn out?	Contact TOUA for replacement
	Check high pressure cap joint insert to the spark plug.	High pressure cap joint insert to the spark plug.
	Check spark plug, grease or debris?	Clean the foreign body.
	Check filter, clogged?	Cleaning or Contact TOUA for replacement.
Fan does not operate when push lever is pressed.	Note the color of the light indicator.	If red: charge the battery. If green: Contact TOUA for replacement.
Unable to charge battery	Inspect if the battery temperature within require range 50°F(10°C) ~ 104°F (40°C).	Wait the battery temperature as the normal range then to charge.
	Check if all joints are inserted and the battery pack Insert in place.	Insert all plugs and ensure the battery pack insert in place.
	Utility voltage not nearly of rated voltages shown on adapter nameplate.	Select and use correct utility voltage to charge. If also can not charge, contact TOUA for replacement.
	The battery pack loosen after inserted in the charger base.	Contact TOUA for replacement.

EXPLODED DRAWING AND PARTS LIST GAS CONCRETE NAILER

MODEL: GSN65D

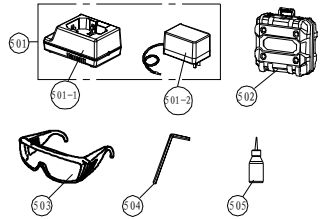
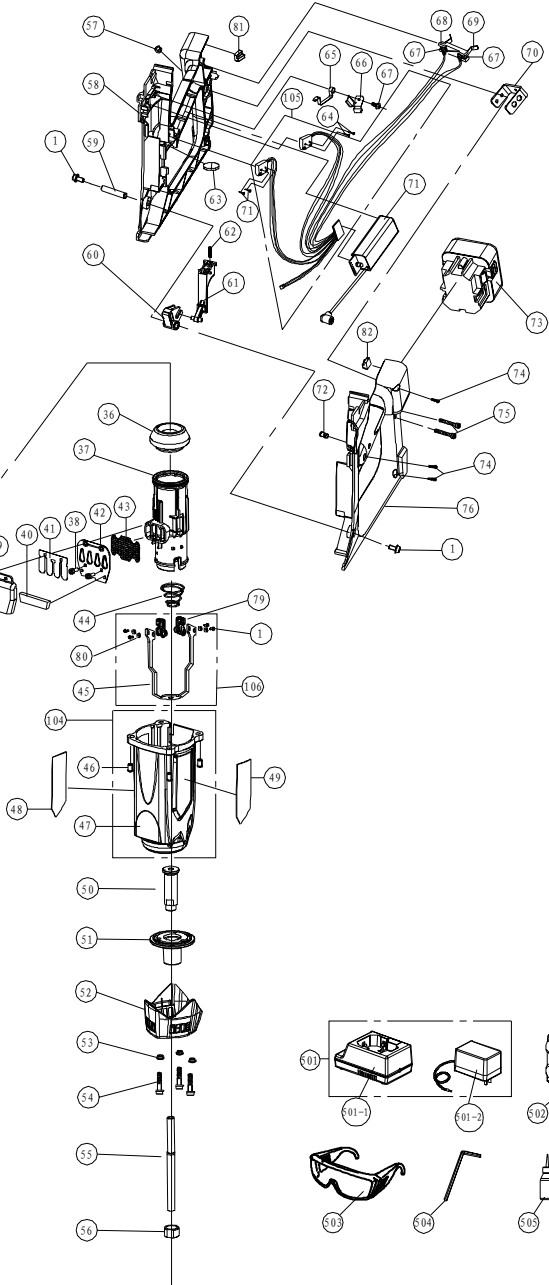
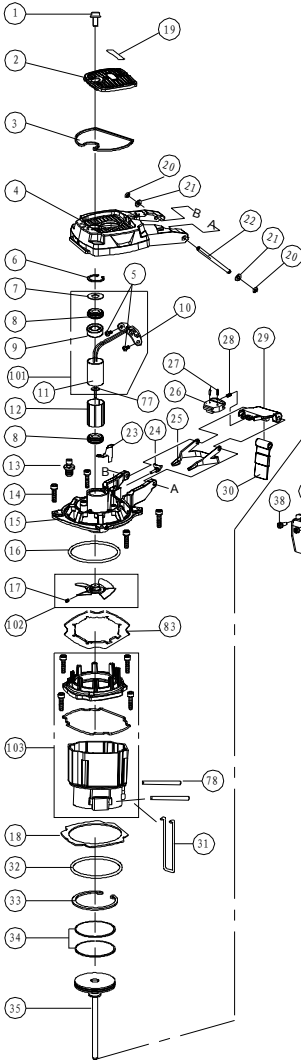

Notes:

Torque(Nm)	Ltem	Remark
1~1.2	17 71 84 9	Loctitle277
1.8~2	5 38 74 81	
3~3.5	40	Loctitle277
	58 82	
3.5~4	1 109	
	1-a	Loctitle277
5.5~6	14 54	
	55	Loctitle272

PART LIST GSN65D

Note : ★ consumable parts

No.	Parts Name	Qty	
1	Hex Bolt M5×10	7	
2	Top Cover	1	
3	Filter	1	
4	Filter Cover	1	
5	Cross Recessed Bolt M4×10	2	
6	Retaining Ring d0=24	1	
7	Gasket	1	
8	Rubber Gasket	2	
9	Washer	1	
10	Motor PCB Board Assembly	1	
11	Motor	1	
12	Mount Sleeve	1	
13	Spark Plug	1	
14	Hex.Socket HD M5×20	4	
15	Cylinder Head	1	
16	O-Ring 63×3.53	1	★
17	Holding Screw M4×5	2	
18	Chamber clapboard	1	
19	Top Name Plate	1	
20	O- Retaining Ring 3.5 ×2	2	
21	Washer d=5	5	
22	Shaft	1	
23	High Pressure Wire Platen	1	
24	Adapter	1	★
25	Cell Lever	1	
26	Latch	1	
27	Spring Straining Pin 2 ×8	2	
28	Latch Spring	1	
29	Cell Cover	1	
30	Cell Rubber	1	
31	Lock Bar	1	
32	O-Ring 70×3.53	1	★
33	Retaining Ring d0=62	1	
34	Piston Ring 60X0.8	2	★
35	Piston Assembly	1	
36	Piston Bumper	1	
37	Cylinder	1	
38	Hex.Sockeeet HD.Bolt M4×10	4	
39	Buffer Cover	1	
40	Muffler	1	
41	Lead Valve	1	★
42	Read Plate	1	
43	Exhaust Baffle	1	
44	Pushing Arm Spring	1	
45	Pushing Arm	1	
46	Nut M5	4	
47	Housing	1	
48	Name Plate	1	
49	Specification Plate	1	
50	Catheter	1	
51	Nail Seat	1	
52	Protect Cover	1	
53	Baffle	3	
54	Hex.Socket HD M5×25	3	
55	Nailer Mouth	1	★
		1	★
56	Locknut	1	
57	Locknut M5	2	

No.	Parts Name	Qty	
58	Right Handle	1	
59	Rotating shaft	1	
60	Lock block	1	
61	Trigger	1	
62	Trigger spring	1	
63	Fuel cell sponge	1	
64	Screw ST2.2×11	4	
65	Switch spring	1	
66	Wiring cover	1	
67	Screw ST2.9×8	3	
68	Internal wire board	1	
69	Battery terminal	2	
70	Hook	1	
71	Controller Assembly	1	
72	LED Light	1	
73	Battery Pack	1	
74	Countersunk Screw ST4.2×20	3	
75	Hex.Socket HD.Bolt M5×35	2	
76	Left Handle	1	
77	Dust shield	1	
78	Parallel pin	2	
79	Tapping arm connecting pieces	2	
80	Tapping arm pin sets	4	
81	The right handle damping block	1	
82	The left handle damping block	1	
83	rubber pad	1	
101	Motor Assembly	1	
102	Wind leaf component	1	★
103	Chamber components	1	
104	Chassis components	1	
105	Mehradrer Plug Assembly	1	
106	Tapping arm components	1	
501	Charger components	1	
501-1	Charger Base	1	
501-2	Adapter	1	
502	Case Assembly	1	
503	Safety Glasses	1	
504	Hex.Bar Wrench M5	2	
505	Oiler	1	

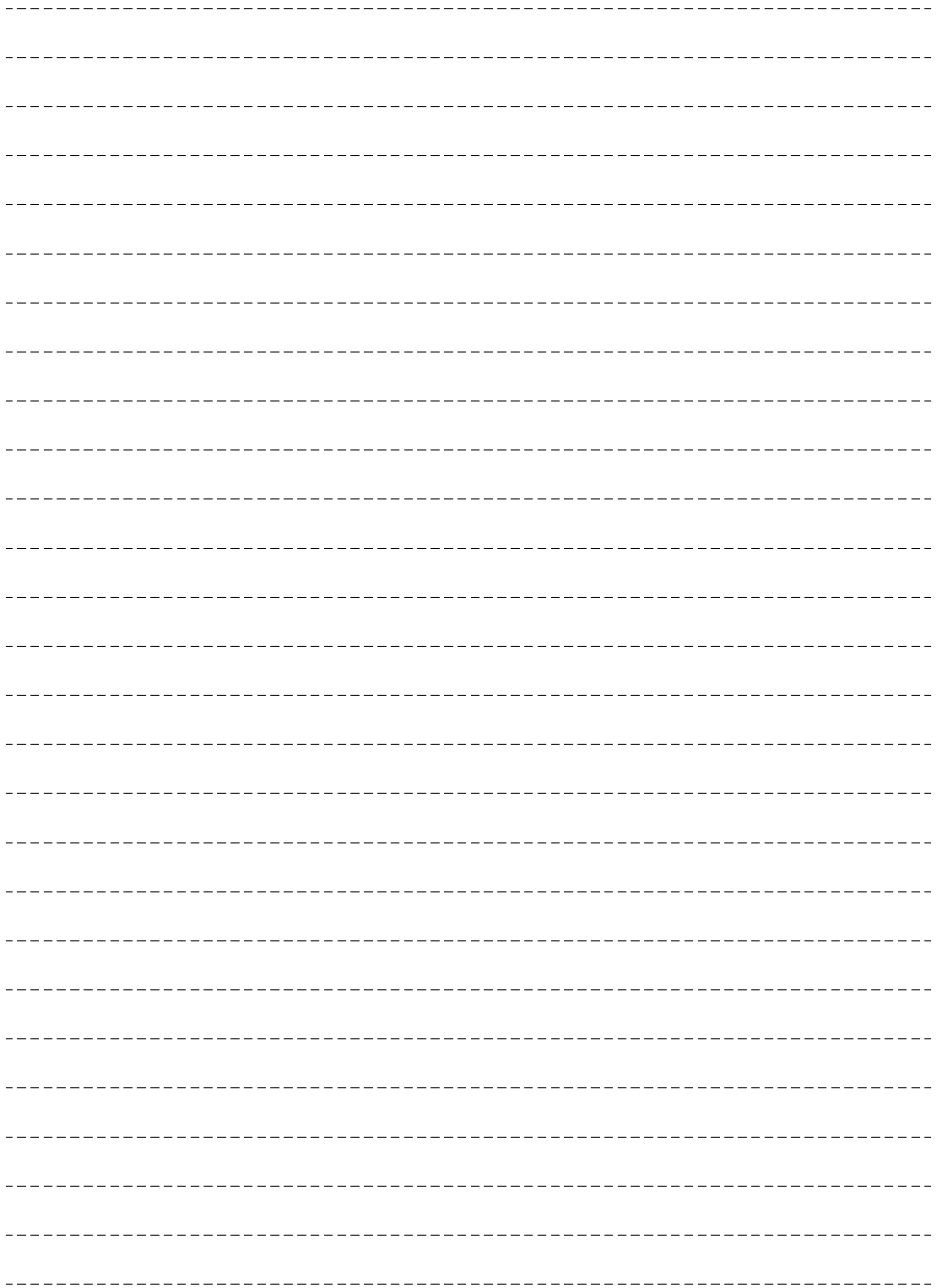

Nanjing Toua Hardware&Tools Co.,Ltd.
#129 Linqi Road Dongshan Industrial Concentraion Zone of Jiangning,Nanjing,China
Postal Code: 211103
Tel:0086-25-52174012,52174008,52174016,52174019
Email:nails@tengya-nj.com;nails@jssmail.com.cn
Website:www.tengya.com